

END POST

LINE POST

CORNER POST

NOTE:
 AVAILABLE W/ SCH. 40
 OR SCH. 80 POSTS

RIVETED LEVEL RAIL CONNECTIONS

2500 SERIES RAIL

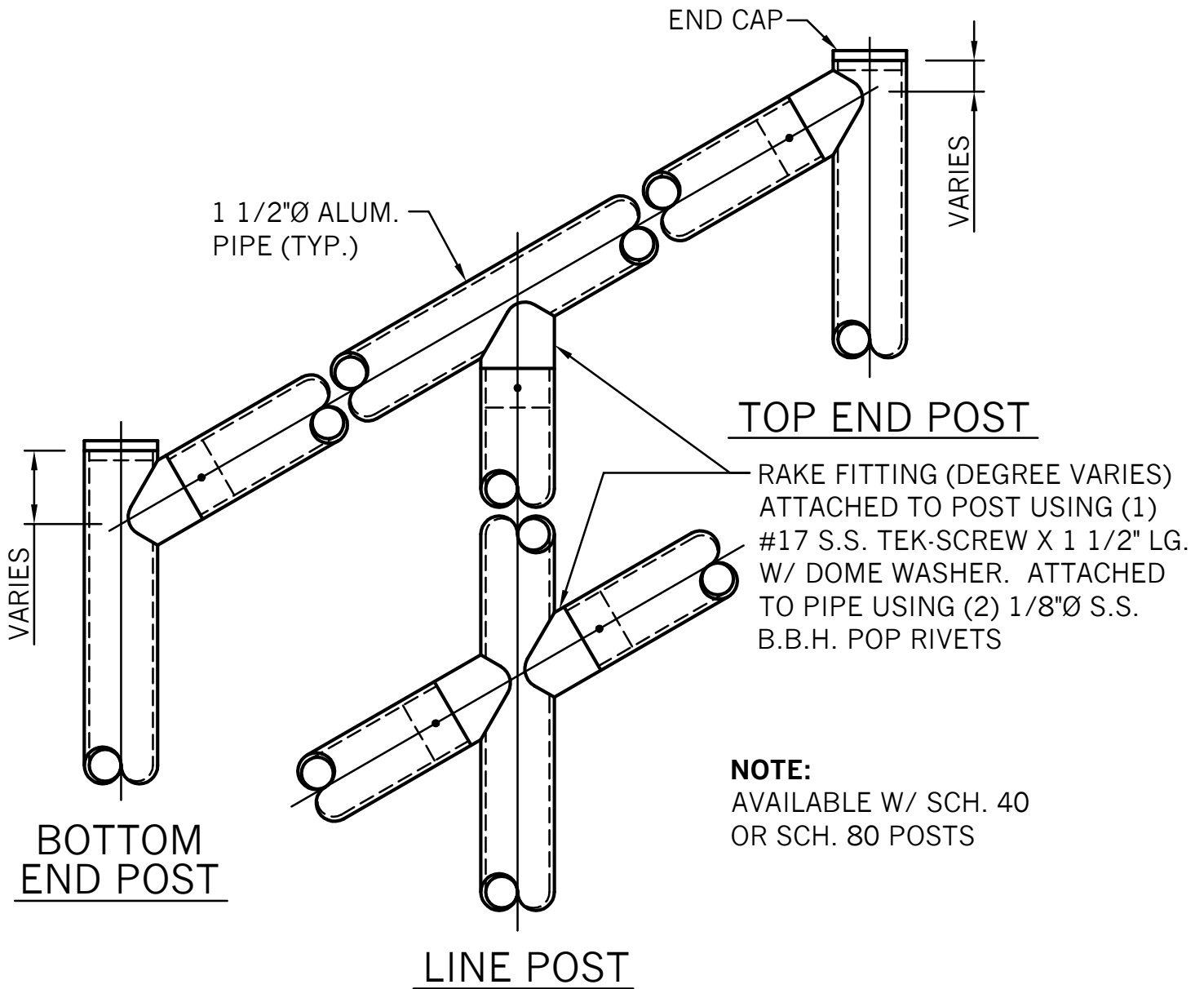

RIVETED RAKE RAIL CONNECTIONS

2500 SERIES RAIL

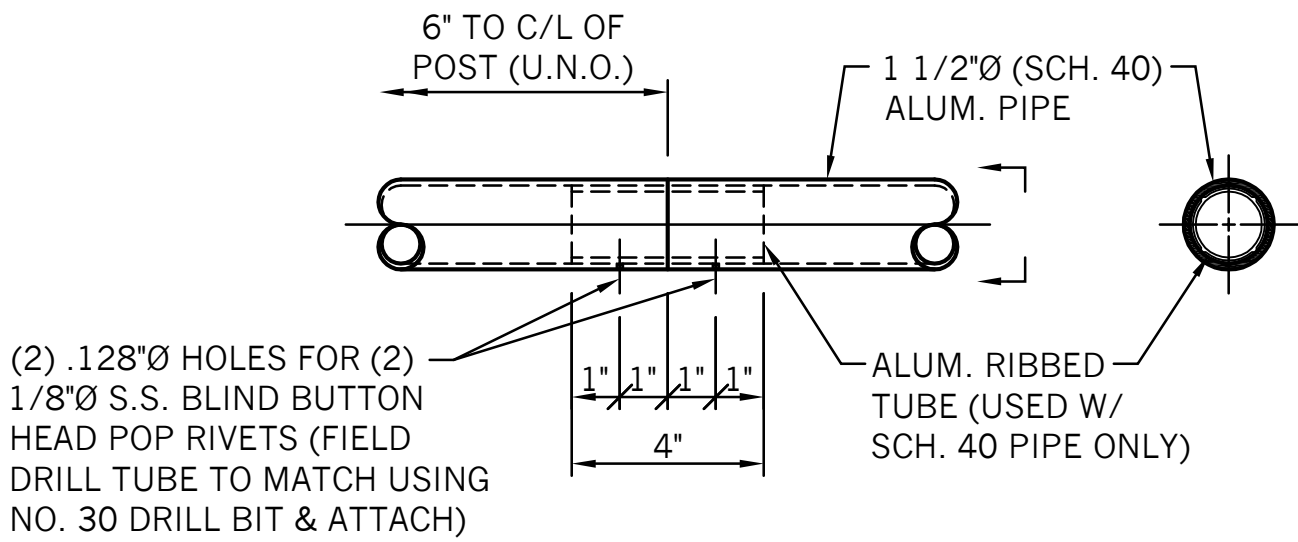

RIBBED TUBE FIELD JOINT

2500 SERIES RAIL

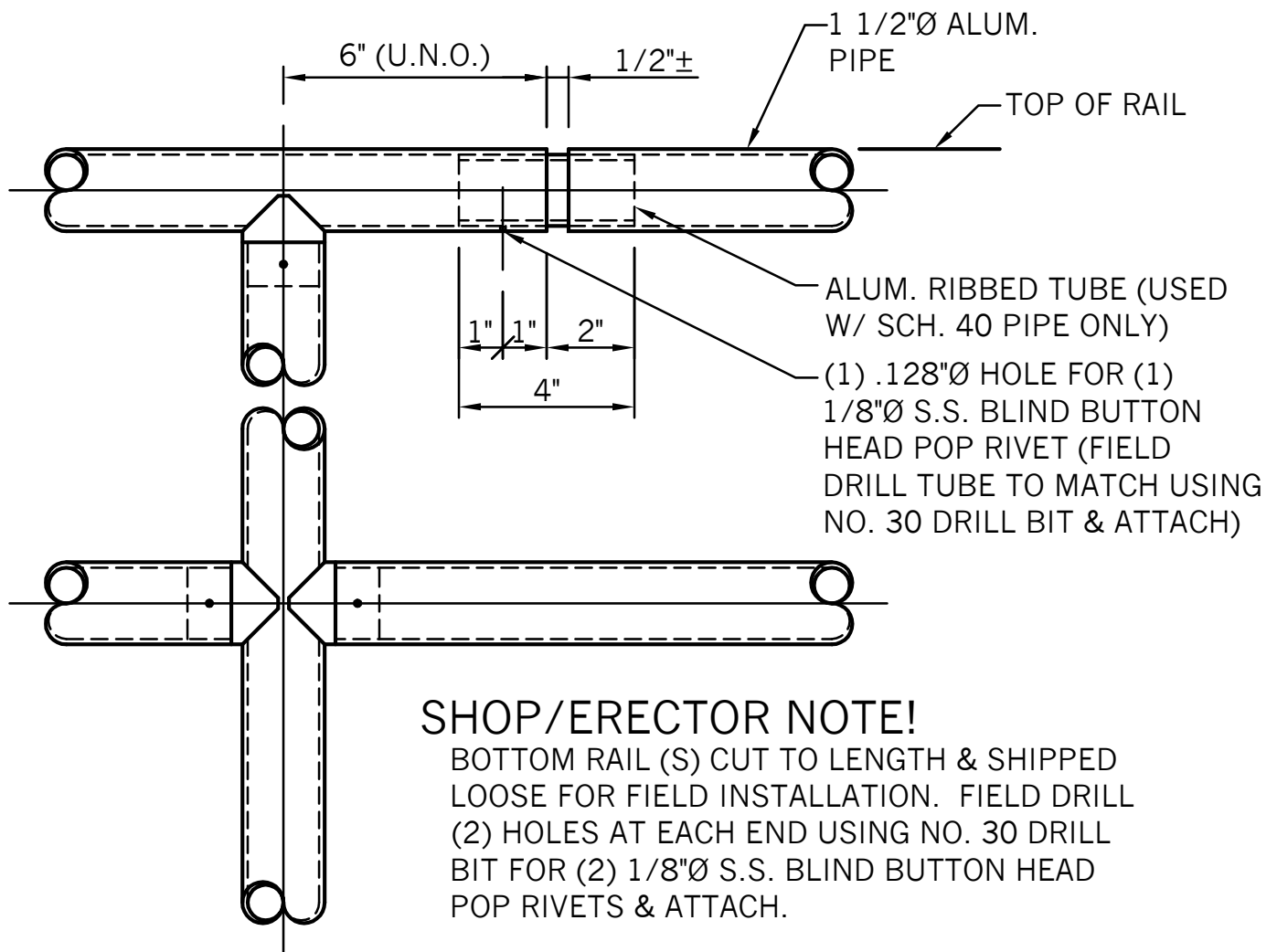

EXPANSION JOINT

2500 SERIES RAIL